

XDM100机械传动自卸车 DRIVE DUMP TRUCK



Head Office :
Jl. Dr. Soepomo No. 37, Tebet Jakarta, INDONESIA 12810
Telp. +621 837 856 79 Fax. +621 837 945 57
Web : www.xcmg-titan.com, cs@xcmg-titan.com



性能参数/ Performance Parameters

额定载重 Rated Payload	91000 kg (100U.S. ton)		
空车重量 Empty Weight	67000 kg		
整车总质量 Gross Vehicle Weight	158000 kg (XCMG system)		
驱动形式 Drive Style	4 × 2		
最高车速 Max. Speed	48Km/h		
最大爬坡度 Max. Gradeability	30%		
最小转弯直径 Min. Turning Diameter	24m		
重量分布 Weight Distribution	空载 Empty	前桥 Front 48%	后桥 Rear 52%
	满载 Loaded	前桥 Front 32%	后桥 Rear 68%
货厢标准容积 Body Capacity	平装 Struck	42 m ³	堆装 2:1 heaped 2:1 60 m ³
外形尺寸 (空载, 长 × 宽 × 高) Overall dimension (EMPTY, L × W × H)	10290 × 5880 × 5085 mm		

主要部件/ Main Parts

发动机 Engine

型号 Model	QST30
额定功率/转速 Rated Power/Speed	783 kW 1050 HP@2100 rpm
最大扭矩/转速 Max. Torque/Speed	4629 Nm @1300 rpm

传动系 Drivetrain

变速箱 Transmission	H8610AR	
驱动桥 Drive Axle	主减速比 Differential	2.16:1
	轮边速比 Planetary	13.75:1
	总速比/Total Reduction	29.70:1

轮胎与轮辋 Tires And Rims

标准轮胎 Standard Tire	27.00R49无内胎、全钢子午线轮胎
	27.00R49 Tubeless, all-steel radial tires
标准轮辋 Standard Rim	49-19.5/4.0

驾驶室 Cab

类型 Type	ROPS&FOPS驾驶室 ROPS&FOPS Cab
---------	----------------------------

制动系统 Brake System

前桥制动 Front Brake	干式制动盘, 总制动面积1960 cm ² Dry disc, diameter Pad area, total 1,960 cm ²
后桥制动 Rear Brake	徐工油冷、湿式制动器、完全隔绝污物与水。总制动面积91,000 cm ²
	XCMG oil cooled, multiple disc, completely sealed from dirt and water. Breaking surface, total 91,000 cm ²

前悬架 Front Suspension

独立悬架, 油气悬架缸	Independent, hydro-pneumatic suspension
-------------	---

液压系统 Hydraulic System

转向 Steering	流量放大式动力转向, 辅助转向由蓄能器自动提供
	Flow amplified power steering. Supplementary steering automatically supplied by accumulators

电气系统 Electrical System

24 V

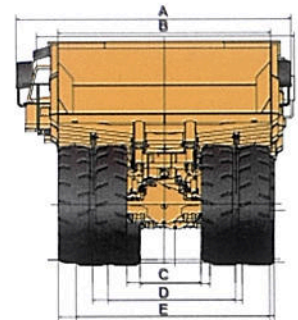

A: 6580 B: 5510 C: 1780
D: 3420 E: 5060

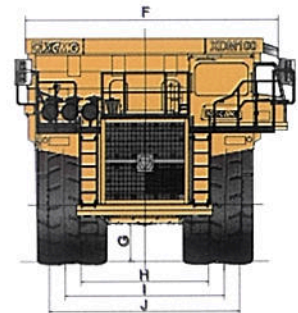

F: 5880 G: 780 H: 3090
I: 3775 J: 4460

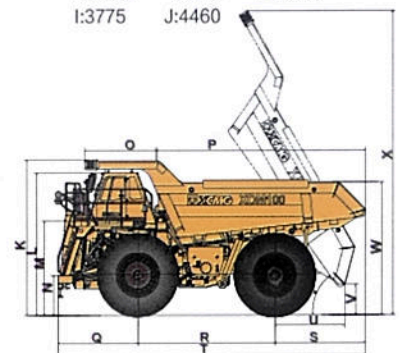

K: 5085 L: 4645 M: 3060 N: 1300
O: 2400 P: 7000 Q: 2673 R: 4580
S: 3037 T: 10290 U: 2300 V: 860
W: 4325 X: 9870